

HOLDEN

Australia's Own Utility





Holden is the only utility with Magic-Mirror Acrylic Lacquer Finish. This gem-hard paint finish, exclusive to GMH, keeps its showroom lustre for up to three years without polishing.

HOLDEN COUPE UTILITY IS WORTH MORE TO YOU

AND OVER 140,000 AUSTRALIAN OWNERS HAVE PROVED IT

Every year since its introduction, Holden Utility has been the first choice of utility operators throughout Australia. The reasons behind this continued sales leadership are of real significance to you. To start with, Holden Coupe Utility is designed specifically for Australia and so it gives you more of the things you want. In addition, Holden's low list price means that you get the best value. But, above all, Holden has proved its dependability and economy. And it's been constantly improved as a result of the experience of over 140,000 Australian owners. In this latest Holden you get still further improvements including new front-end styling, new hub-cap emblems, fine new two-tone upholstery, new electric windshield wipers and a new cabin-controlled bonnet lock. Today—Holden Utility is worth more than ever to you.

WORTH MORE BECAUSE IT HAS BIG LOAD SPACE

Holden Utility has the length, width and height of load area you need to carry bulky loads. And Holden has the strength, too. Its Aerobilt construction, which reduces vehicle weight without sacrificing strength or durability, has proved its worth over millions of Australian miles.

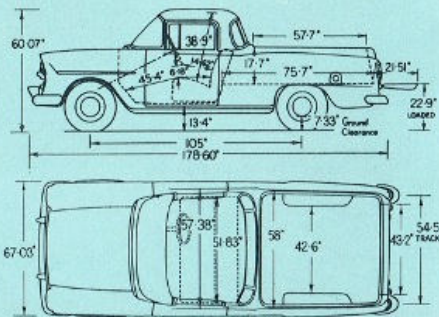

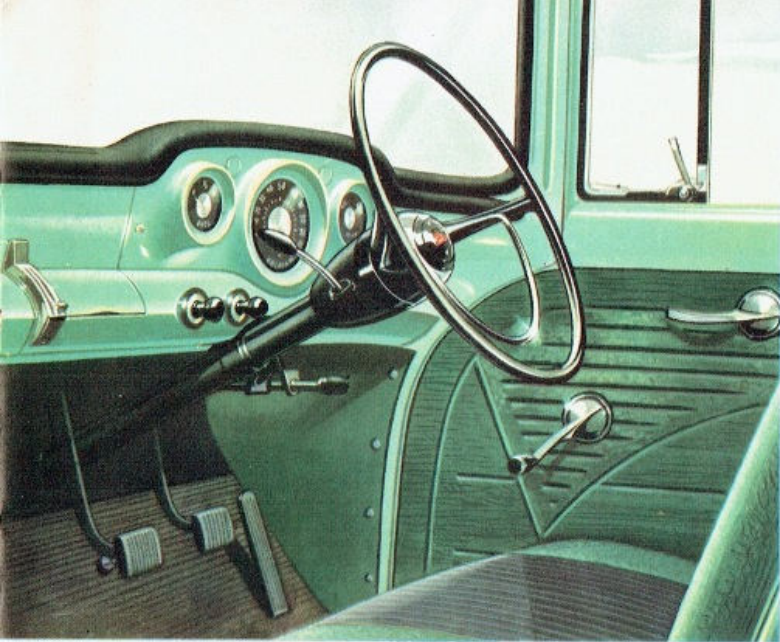

WORTH MORE BECAUSE OF ITS ROOM AND APPOINTMENTS

Holden Utility is a fine-looking vehicle. You'll like driving it . . . on the job, or on social occasions. And the spacious Holden cabin has been designed to give you the utmost in comfort and roominess for three big people. Every design feature is a practical feature. The handsome, new, two-tone PVC upholstery is washable and wear-resistant. The deep, wide windshield and rear window afford first-class visibility of load and road. The deeply dished steering wheel allows a clear, uninterrupted view of the well-planned instrument panel. You get light, yet positive, steering and a driving position that's completely comfortable, even if you are a six-footer. New electric windshield wipers. A tonneau cover is provided as standard equipment at no extra cost.



WORTH MORE BECAUSE OF LOAD-CARRYING ABILITY

Holden Utility's load-carrying record over millions of Australian miles is proof of its capability and dependability. With its long wheelbase and short overhang you get the ideal load balance. Ideal load height of 22.94 inches enables easier loading from ground level. Also, the rear tailgate drops right down for backing up to loading docks and platforms.



WORTH MORE BECAUSE OF AUSTRALIAN DESIGN

Holden Utility is easier to handle . . . gives you a better ride . . . because it is designed specifically for Australian conditions. Holden gives you the right springing, the right steering, and the right ground clearance for Australia. And every improvement and modification to Holden is first tested and proved right for Australia on the GMH Proving Ground at Lang Lang, Victoria — Australia's only automotive proving ground.

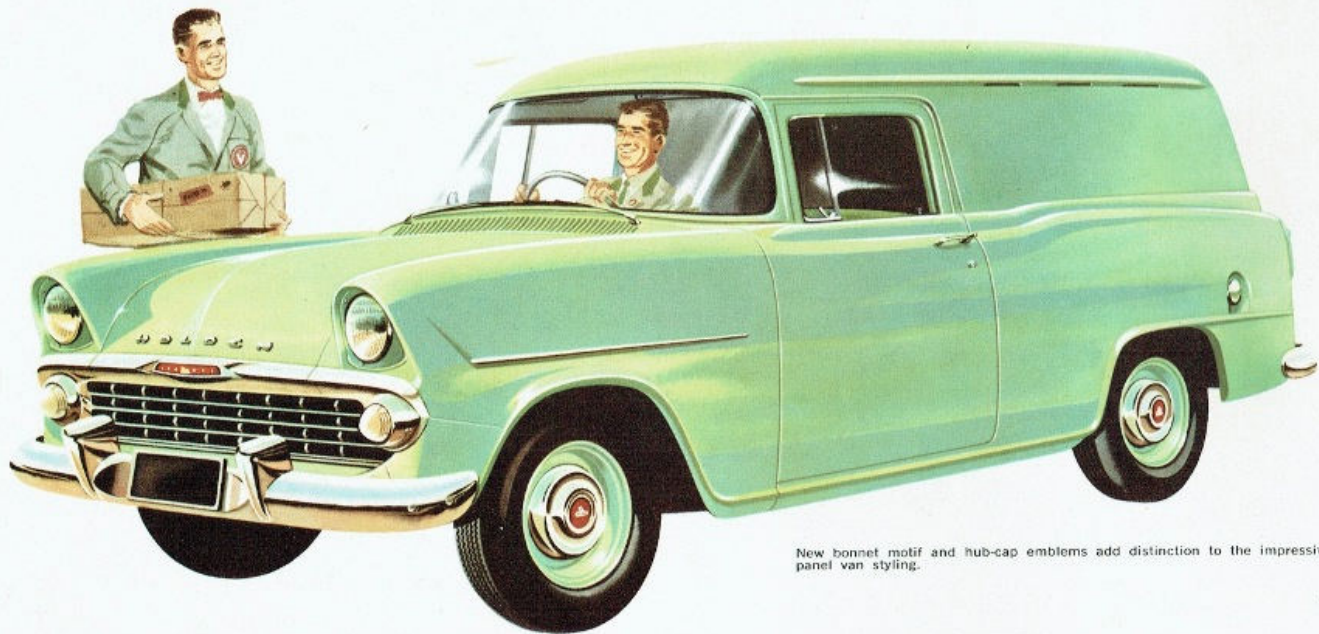

New bonnet motif and hub-cap emblems add distinction to the impressive panel van styling.

HOLDEN PANEL VAN IS BIG, GOOD LOOKING AND A PROVED PERFORMER

What's behind the great success and popularity of Holden Panel Van throughout Australia? Unquestionably, it's the fact that Holden best satisfies the needs of most Australian panel van operators. It gives you more for your money. If you want big load space, Holden has it. If you want real load-hauling performance, Holden gives it to you with a 6-cylinder engine famous for its power and economy. If you want trouble-free operating, you can't go past Holden with its proved record of dependability. Combined with these advantages, Holden gives you fine styling that's been made even more impressive by a completely new radiator grille. Other new features are the electric windshield wipers and the cabin-operated bonnet lock. Now — more than ever — Holden is the best panel van investment you can make.

MORE FOR YOUR MONEY IN CARRYING CAPACITY

Check the dimensions and you will see that the Holden Panel Van has a big, profitable load-carrying area. In fact, you get 77 cubic feet of cargo space. In the cabin there's comfortable seating for three with the head room and leg room necessary for relaxed day-long driving.

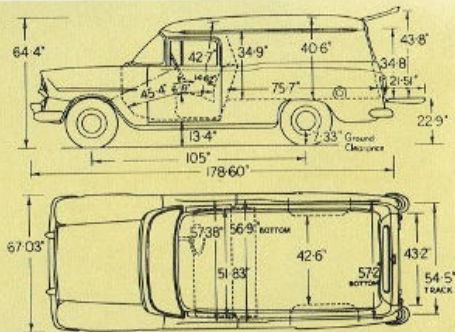

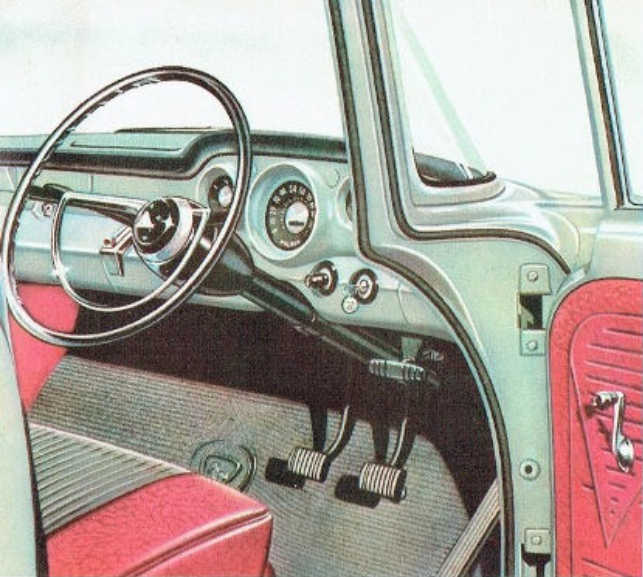

MORE FOR YOUR MONEY IN COMFORT AND FINISH

Holden Panel Van is built for work and plenty of it, but offers cabin comfort and appointments of the highest standard as well. The wide bench seat takes three big people comfortably. Excellent vision is provided by the deep, wide windshield. New, two-tone upholstery is colour-keyed to the new exterior range of sparkling Magic-Mirror Acrylic Lacquer colours.



MORE FOR YOUR MONEY IN LOADING CONVENIENCE

77 cubic feet of load area provides room for real payloads in the spacious Holden Panel Van. The high, wide tailgate opening and top and bottom hinging means loading is easier—even with big, bulky packages in the narrowest laneway. The large safety-glass rear window is standard equipment.

MORE FOR YOUR MONEY IN STYLING

The dignified and impressive styling of the Holden Panel Van adds prestige to any business, and, as you can see, the large side panels can be effectively and attractively used for displaying an advertising message. Holden's smooth flowing lines are highlighted by durable and bright Magic-Mirror Acrylic Lacquer Finish, the GMH exclusive, gem-hard car paint that resists staining, cracking and chipping . . . needs no polishing for up to three years.



THE FAMOUS HOLDEN 6-CYLINDER ENGINE

PROVED FOR PERFORMANCE, ECONOMY

The Holden 6-cylinder engine was acclaimed as a great engine when it was first introduced over twelve years ago. Today it is even better. Improvements and modifications over the years have established that the Holden motor is a masterpiece of automotive engine design. Owner reports bear this out. Very lively . . . no major repairs in over 100,000 miles . . . very flexible in all gears . . . are typical of the comments that are made. The 75-b.h.p. Holden engine gives you power with long life, performance with good petrol economy, plus renowned reliability and low repair cost. Well over 775,000 Australian owners have proved the worth of this famous engine.

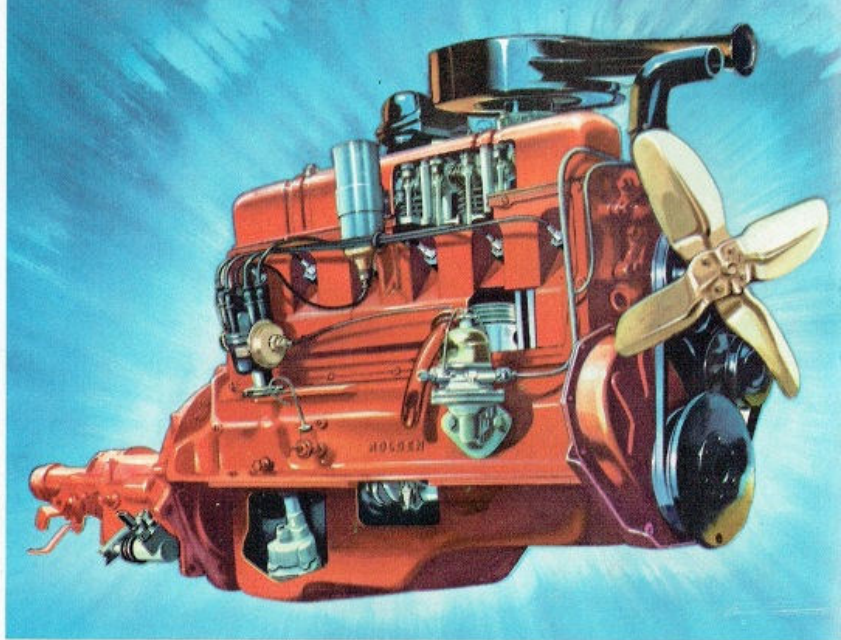

ALL-ROUND BETTER HANDLING QUALITIES

Holden's all-round better handling qualities are immediately noticeable. The easy operation of the silent 3-speed gear box . . . the instant response you get from Holden's recirculating ball-type steering . . . the tight 36½-ft. turning circle . . . all these things make driving easier in heavy traffic, narrow streets and congested parking areas.



MORE IN COMFORT, DRIVING PLEASURE

Holden's bench seat with closely set "Z"-type seat springs gives you passenger-car comfort. Balanced Holden springs, wide track and long wheelbase mean you get a better "ride", more stability and safety. And the convenient plenum chamber system of ventilation enables you to have a constant flow of fresh air in the cabin even when the windows are closed.

GMH PROTECTIVE MAINTENANCE PLAN

GIVES YOU SAVINGS
... CONVENIENCE



As a Holden owner, you will receive with your new Holden a GMH Protective Maintenance Plan Booklet. This booklet of tear-out coupons sets out an efficient maintenance routine and establishes fixed labour times. The GMH Protective Maintenance Plan saves you money by keeping your Holden in top condition. It shows at trade-in that your car has been regularly serviced. In addition to the Protective Maintenance Plan, the well-known GMH Warranty protects you against defective workmanship or materials for 90 days or 4,000 miles of operation. Through the GMH owner service policy you are also entitled to two thorough inspections and adjustments of your Holden without charge at 1,000 and 2,000 miles. Expert Holden Service and a supply of low-cost, factory-guaranteed parts are available wherever you may drive from over 600 Holden dealers throughout Australia.

PROVED HIGH RESALE VALUE

Holden Utilities and Panel Vans bring high prices on the used-car market. This is because they have proved themselves thoroughly dependable, exceptionally economical on the job. Holden advances like Magic-Mirror Acrylic Lacquer Finish and the GMH Protective Maintenance Plan add further to Holden resale value. Your investment is protected when you buy a Holden!

HOLDEN* UTILITY AND HOLDEN* PANEL VAN ABRIDGED SPECIFICATIONS

MECHANICAL

ENGINE: 6-cylinder, O.H.V. design. Bore, 3-1/16 in. Stroke, 3-1/8 in. Displacement, 138.0 cu. in. S.A.E. or R.A.C. rating, 22.5 h.p. Max. gross brake horsepower, 75 at 4,200 r.p.m. Max. gross brake torque, 120 lb./ft. at 1,400 r.p.m.

COMPRESSION RATIO: 7.25 to 1.

CRANKSHAFT: Drop forged, fully counter-balanced, with harmonic balancer.

PISTONS: Aluminium alloy.

CAMSHAFT: Four-bearing steel forging.

OILING SYSTEM: Full pressure system.

FUEL SUPPLY: Bendix Stromberg double venturi down-draught type carburettor. Throwaway A.C. dry element filter-type air cleaner and silencer.

COOLING: Cellular-type radiator with pressure cap. Water pump.

ELECTRICAL SYSTEM: Centrifugal and vacuum-type distributor advance control. Octane selector. Battery — 12 volt, 9 plate. Headlamps. Parking lamps. Dimmer switch. Dome lamp with integral switch. Tail, stop and licence plate lamps. Provision for installation of optional flashing light direction indicators. Centralised fuse block.

TRANSMISSION: 3-speed with helical gears. Synchromesh for second and high speeds. Ratios: 1st, 2.99 to 1; 2nd, 1.59 to 1; 3rd, direct; reverse, 2.99 to 1.

CLUTCH: Hydraulically actuated.

REAR AXLE: Banjo construction, semi-floating. Ratio: 3.888 to 1.

BRAKES: 4-wheel hydraulic.

HANDBRAKE: Operates mechanically on rear brakes.

WHEELS: Demountable disc, size 13 x 4.50J.

TYRES: Tubeless low-pressure balloon, 6.40—13 x 6-ply.

STEERING: Recirculating ball type. Gear ratio: 14 to 1. Turning circle: 36.5 ft.

FRONT SUSPENSION: Independent coil spring, short and long arm type.

REAR SUSPENSION: Hotchkiss drive with 6-leaf heavy-duty semi-elliptic springs.

SHOCK ABSORBERS: GMH Delco. Tubular telescopic, direct acting.

BODY

BODY STRUCTURE: All-steel "Aerobilt" body, with chassis and body built as one unit. Alligator-type locking hood.

DIMENSIONS: Wheelbase, 105 in.; overall length (with bumpers), 178.6 in.; overall width, 67.03 in.

INSTRUMENT PANEL: Indirectly lighted. Includes combined ignition and starter switch, choke, speedometer, petrol gauge, temperature, oil pressure and generator charging warning lights, lighting switch. Glove box with locking lid. Electric windshield wiper control. Air intake control lever.

EQUIPMENT

EQUIPMENT—CHASSIS: Dual electric windshield wipers. Front bumper. Rear bumperettes.

EQUIPMENT—BODY: Washable PVC upholstery and headlining. Sun visors. Rear view mirror. Ashtray. Safety-glass windows. Floor covering—rubber mat. Load compartment floor boards of laminated plywood and Masonite with steel skid strips. Open grille air-intake ventilation. Safety-glass one-piece windshield. Full width window in upper tailgate of Panel Van. Fully adjustable seat fitted with "Z"-type springs. Externally operated door lock L.H. front door. Bonnet lock fitted both models. Hold-open checks both doors. Tonneau cover with Utility.

TOOLS: Tool container, combination pliers, screwdriver, wheel-nut and spark-plug wrench, jack and handle, and wheel-nut wrench handle.

KERB WEIGHT: Utility, 2,452 lb. (approx.). Panel Van, 2,511 lb. (approx.).

MAX. G.V.W. UTILITY: 32 cwt.

MAX. G.V.W. PANEL VAN: 32½ cwt.

G.M.A.C.'s Confidential Hire Purchase Plan is available for your convenience.

GENERAL MOTORS-HOLDEN'S PTY. LIMITED

BRISBANE • SYDNEY • MELBOURNE • ADELAIDE • PERTH

HOLDEN

Australia's Own Panel Van

