

HILLMAN MINX

DE LUXE SALOON

A ROOTES PRODUCT

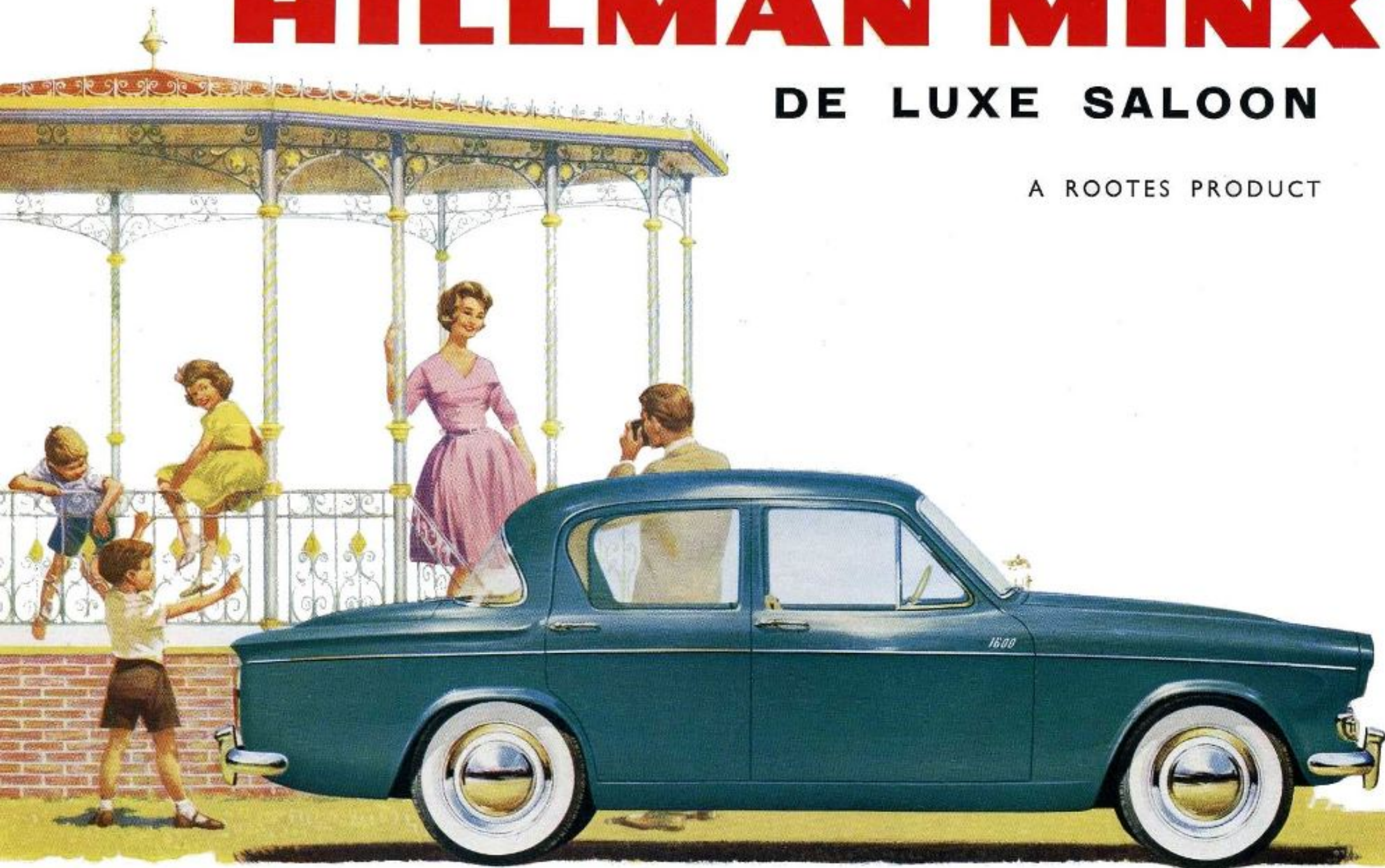

Greatly improved • Larger Engine • Lower price

For Luxury Motoring at Lower Cost

HILLMAN MINX

DE LUXE SALOON



Now the Hillman Minx de Luxe Saloon is an even finer car than before – yet costs less! With its mechanical refinements, luxury comfort, high quality and proven reliability, the new Hillman Minx de Luxe Saloon is outstanding value – and the best family car buy of today!

In this de Luxe Saloon you have the brilliant engineering and design and the superior craftsmanship for which Hillman is long famous. Hillman reliability and performance have been proved on the roads of the world. With the larger '1600' engine, you also have high cruising speeds and improved fuel consumption, together with sparkling performance and vivid acceleration.

Modern and elegant in its styling, it is extremely attractive in appearance with a distinctive radiator grille, and an impressive side moulding in chrome. A deep, wide windscreen and curved backlight give all-round vision. The interior is ideally planned to a high standard of luxury, with richly upholstered seating and all amenities for driver and passengers.

You must experience the new Hillman performance yourself – backed by the stamina and endurance for which Hillman is famed everywhere. Competition successes in South and Central Africa, Canada, Australia, Tasmania and in Europe have shown repeatedly the car's superior qualities, its design, engineering excellence, workmanship and performance under the most varied conditions – its strength, reliability and safety. Because of its compact proportions and all-round vision, you will find the Hillman Minx easy to manoeuvre and park. The efficient suspension system gives a smooth, even, road-hugging ride of great stability and safety when cornering. For extra safety, you have the smooth, progressive braking of powerful large-diameter drum brakes, matching the new performance, and the all-round protection of Hillman unitary construction – body and chassis welded into one immensely strong, all-steel unit.

Only from the fine traditions of Hillman could there come a car combining such beauty and elegance with brilliant performance, so enjoyable to drive and so very practical for business and pleasure.

FULLY-AUTOMATIC TRANSMISSION is available as an extra, eliminating clutch pedal and gear lever. It brings you effortless motoring, with Hillman performance and economy. Your Hillman Dealer will give you full details.

White-wall tyres, overriders and rimfinishers are available as extras.



The car with a style of its own . . .

and a famous world-wide reputation

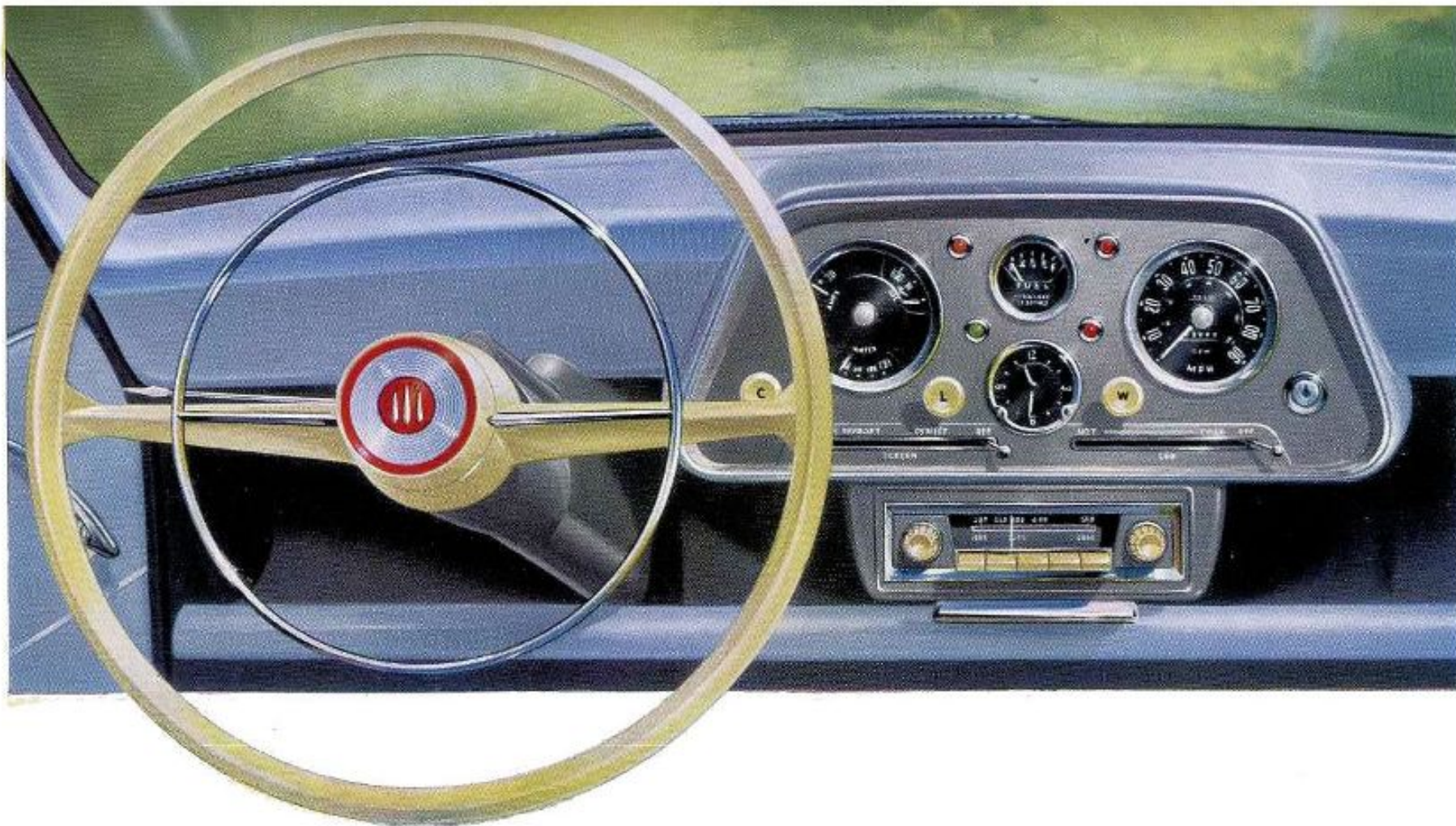

Controls ready to hand

Here is your driving position – expertly designed, with instruments grouped for reading at a glance. The steering wheel is angled for ease of control and has a full-circle, finger-tip ring which operates the dual wind-tone horn. You will appreciate the quick operation of the combined side and headlamp switch – and the new mileage trip recorder embodied in the speedometer. A

curved, large-area windscreen gives panoramic vision – makes driving easier and infinitely safer. The scientifically designed front seating is adjustable and provides perfect body support for relaxed driving, with generous headroom and legroom. Below the smart, stylish fascia panel is a useful parcels tray. Provision is made for radio, heater, clock, ammeter and oil gauge as extras.

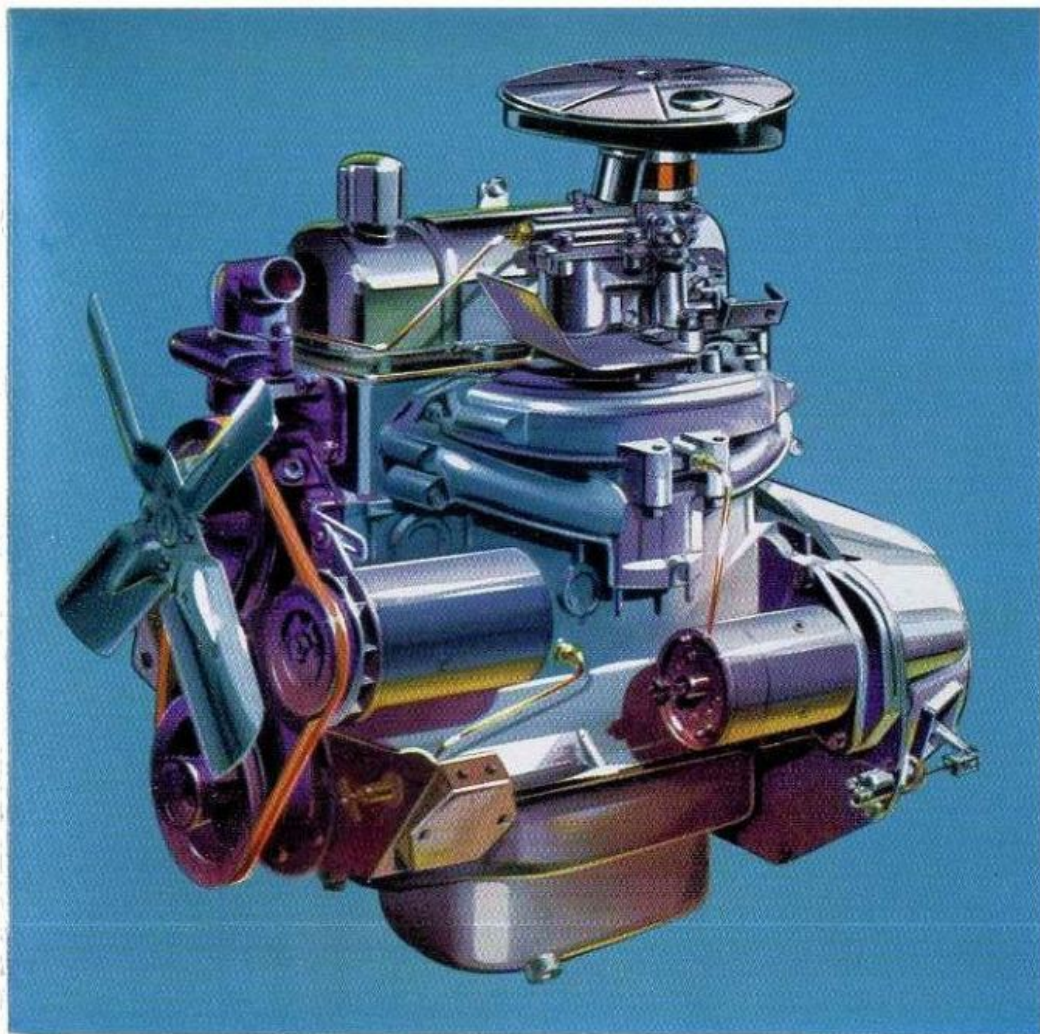

New "1600" Hillman Engine

Smoother Performance, greater fuel economy

A larger engine now powers the Hillman Minx de Luxe Saloon. A precision-built unit of modern, short-stroke design, it has a capacity of 1,592 c.c. and develops 56.5 b.h.p. at 4,100 r.p.m. It combines a powerful, spirited performance with great reliability, quiet running, improved fuel economy and high cruising speeds. Inlet and exhaust manifolds of advanced design give smooth operation and the engine is cushion-mounted to absorb noise and vibration. Improved torque characteristics add thrust in the lower speed ranges – a boon when driving in town or overtaking. Acceleration through the gears is brisk, and the latest type carburettor economises on fuel and cuts running costs. Steering maintenance is simplified by the introduction of greaseless nylon joint inserts at the outer track rods.

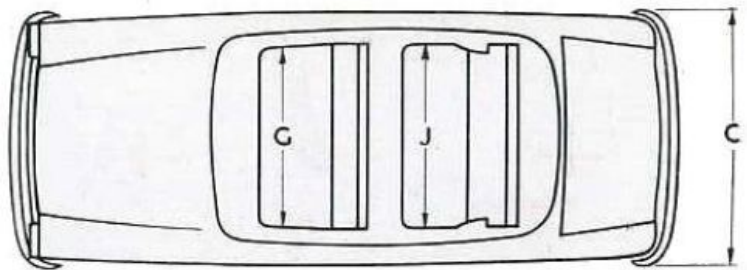
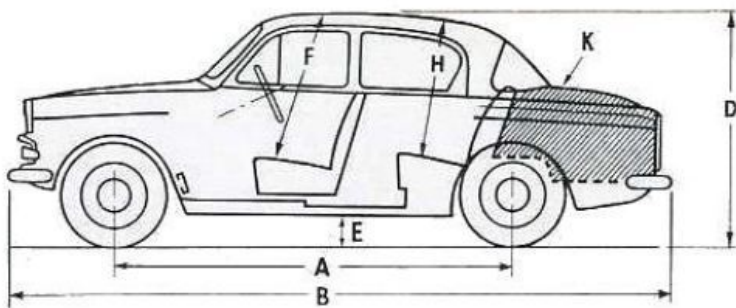

DIMENSIONS

		in.	m.
A	Wheelbase ...	96	2.438
B	Overall Length ...	162	4.115
C	Overall Width ...	60 $\frac{3}{4}$	1.543
D	Overall Height ...	59 $\frac{1}{2}$	1.511
E	Ground Clearance ...	7	0.178
F	Front Headroom...	38 $\frac{1}{2}$	0.978
G	Front Seat Width ...	47	1.194

		in.	m.
H	Rear Seat Headroom ...	36 $\frac{3}{4}$	0.933
J	Rear Seat Width...	50	1.270
K	Luggage Compartment Capacity ...	13 $\frac{1}{2}$ cu. ft.	0.382 cu. m.
		in.	m.
	Front Track ...	49	1.245
	Rear Track ...	48 $\frac{1}{2}$	1.232
	Turning Circle ...	36 ft.	10.973

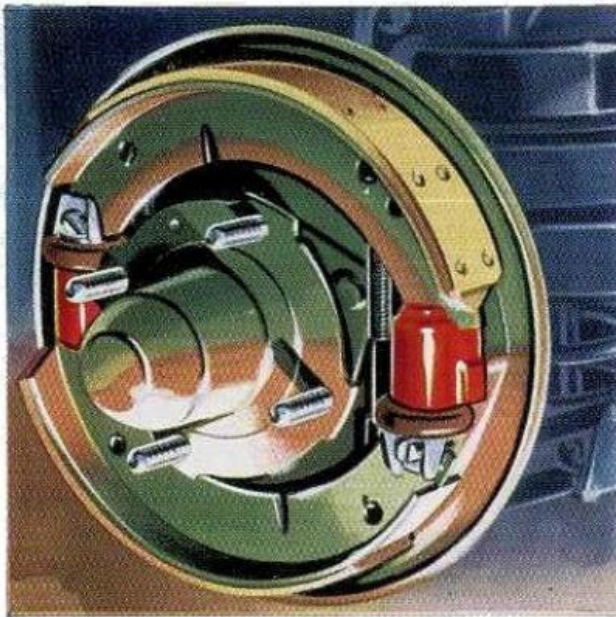

Large, 9-inch diameter drum brakes give smooth, progressive braking and great safety. Brakes have a total lining area of 121 sq. inches (708 cm.²), are very resistant to fade, last longer and considerably reduce pedal load.

Hypoid final drive rear axle unit, with semi-floating hubs, has a ratio of 4.22 : 1. Thick rubber cushions insulate the axle from the suspension.

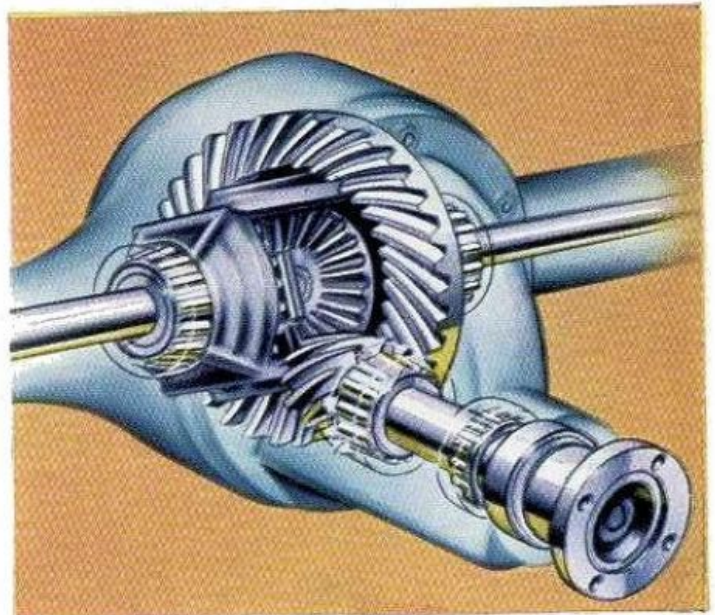

Travel in luxury comfort

This is the roomy, beautifully appointed Hillman interior – planned for driving ease and relaxed travel, with fine styling and quality finish, a smart interior trim and discreet use of chrome. The wide, spacious seats, deeply sprung and cushioned in foam rubber, give ample headroom and legroom. The front seat can be quickly adjusted to your preferred driving position. Everything is designed for comfort and convenience. Driver and passengers have a sweeping view through the wide expanse of window. A convenient sports type floor gearchange lever is standard fitting, and steering column gearchange is available, if required. There are twin sun visors, and an interior courtesy light operates when the front doors are opened.

From the rear, too, you note the elegance of smooth, air-flow design – the neat styling of the oval tail light clusters embodying flashing indicators, reflectors and stop lamps – and the wide opticurve backlight which gives excellent rearward vision that facilitates parking and reversing. An ample-size luggage compartment, with lockable, spring-assisted lid, has protective floor mat and is well sealed against weather conditions.

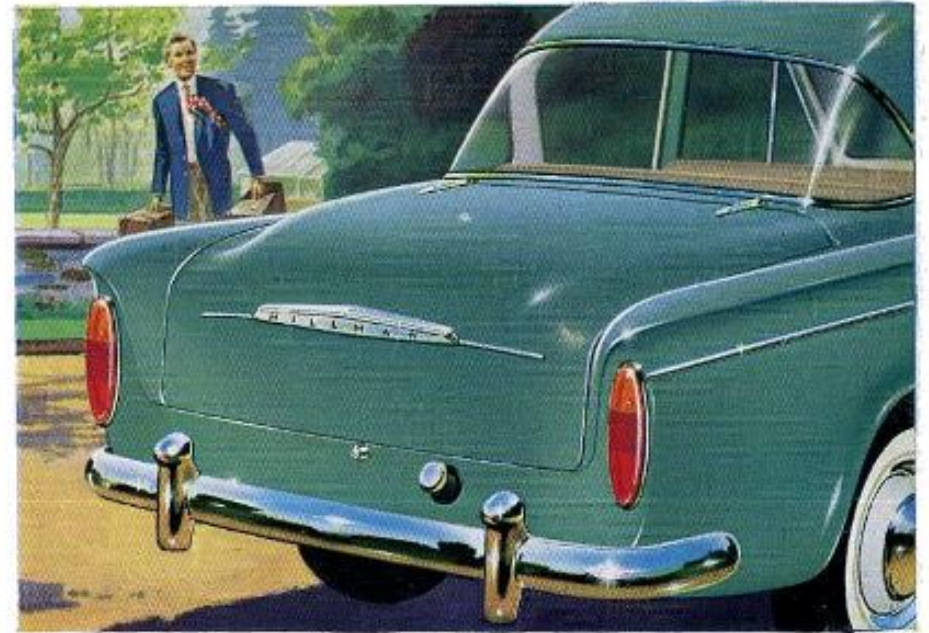

HILLMAN MINX

HILLMAN MINX DE LUXE SALOON

SPECIFICATION

Engine. Four-cylinder short stroke unit with push rod operated overhead valves. Zenith down-draught carburettor.

Bore and stroke 3.21 in. (81.5 mm.); 3.00 in. (76.2 mm.)

Cubic capacity 97.1 cu. in. (1,592 c.c.).

Engine develops maximum b.h.p. 56.5 at 4,100 r.p.m. with 8.3 : 1 compression ratio. (For certain markets a low compression ratio is available, for details ask your Dealer.)

Ignition. 12 volt battery housed under bonnet, oil filled coil; distributor embodies automatic advance and retard and addition vacuum control. Champion N5 sparking plugs.

Cooling System. Centrifugal pump and 4 bladed fan; thermostatic control for more rapid warm-up; pressurized radiator; selective cooling by jets of exhaust ports and sparking plug bosses.

Clutch. 8 in. (203 mm.) diameter single dry plate, hydraulically operated from pendant pedal.

Gearbox. Four-speed gearbox with light action control ring synchromesh on top, 3rd and 2nd gears. Centre floor gearchange is fitted; steering column gearchange is available.

Overall ratios. Top 4.22 : 1, Third 5.877 : 1, Second 9.038 : 1, First 15.816 : 1, Reverse 21.088 : 1

Rear Axle. Hypoid semi-floating design. Ratio 4.22 : 1.

Unitary Construction of chassis and body forming a single structure of immense strength and rigidity.

Front Suspension. Fully independent front wheel suspension employing silico manganese coil springs and swinging links.

Telescopic shock absorbers housed down the centre of the coil springs maintain effective control. A torsion bar sway eliminator is fitted between the suspension lower links.

Rear Suspension. Semi-elliptic leaf springs with dual rate characteristics to suit various loading conditions. Telescopic type shock absorbers.

Wheels. Five pressed steel wheels with wide-base rims. Spare wheel held vertical in well on right-hand side of luggage compartment.

Tyres. Tubeless cushion 5.60 x 15 in.

Brakes. Latest Lockheed two-leading-shoe system with hydraulic operation; cast iron, 9 in. (229 mm.) diameter brake drums; 121 square inches (780 cm.²) of lining area. Handbrake at side of driver's seat operates mechanically on rear wheels.

Steering. Burman recirculating ball type with three-piece symmetrical track rod linkage: Two-spoke steering wheel. Left- or Right-hand drive available according to market requirements.

Petrol Tank. 7½ Imperial gallon (33 litres) capacity positioned below the luggage compartment floor.

Weights (approx.) Unladen (with petrol and water): 2,237 lb. (1016 kg.).
Dry (without petrol and water): 2,172 lb. (985 kg.).

COLOUR SCHEMES

Single Tones:

Body Upholstery

Embassy Black	Bright Red
Powder Blue	Powder Blue/Charcoal
Foam White	Bright Red
Lake Blue	Lake Blue/Charcoal
Glen Green	Regency Beige
Thistle Grey	Bright Red

Two Tones:

Lower Body	Upper Body	Upholstery
Charcoal	Powder Blue	Powder Blue/Charcoal
Glen Green	Foam White	Glen Green
Lake Blue	Foam White	Lake Blue
Venetian Red	Foam White	Grey

Optional Extras. The following extras are available ex-factory at extra cost and can only be specified at the time of placing the order: Smiths Radiomobile, Ekco or Pye radio. Heating and ventilating equipment; steering column gearchange; also White-wall tyres.

FULLY-AUTOMATIC TRANSMISSION. (Incorporating Smiths Automatic Transmission) is available as an extra. No system is simpler to handle or more completely automatic. Ask your Dealer for details.

Special Accessories (available at extra cost). A very full and attractive range of accessories is available, including clock, oil gauge, ammeter, overriders, reversing light, rim finishers, etc. Full details can be obtained from your Rootes Dealer.

EXPORT ROOTES DIVISION

DEVONSHIRE HOUSE · PICCADILLY · LONDON W1

The Company reserves the right to alter any prices or specifications at any time, without notice, and all goods are sold subject to prices and Conditions of Sale ruling at the time of delivery.

Sales and Service in 163 Countries

