

# DONKERVOORT

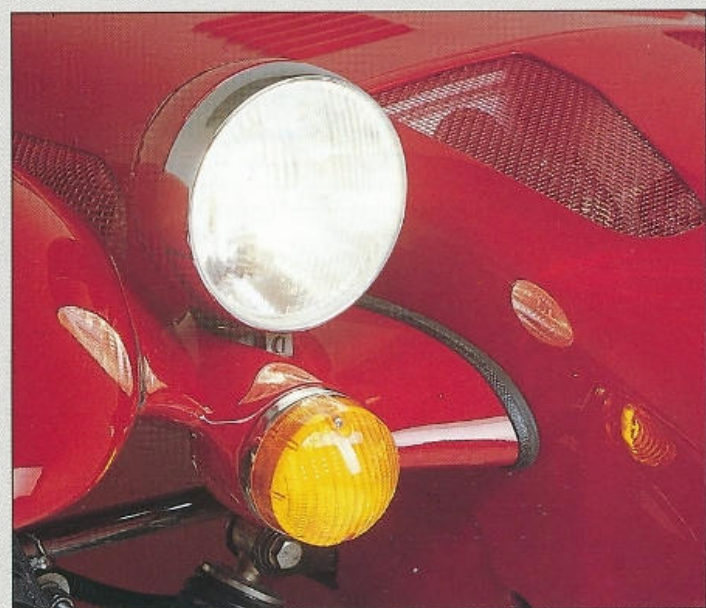

S8AT







# DONKERVOORT

EXCELLENCE IN ENGINEERING

## TECHNICAL SPECIFICATIONS

Donkervoort 58AT	
<b>ENGINE</b>	
mounting	front
cylinders	4 in line
capacity	1993 cc
bore x stroke	90.82 x 76.95 mm
compression ratio	8.0 : 1
max. power	170 bhp [125 kW]
at	5500 rpm
max. torque	23.4 mkg [230 Nm]
at	4000 rpm
camshaft mounting	overhead
cooling	hybrid
fuel injection	electronic (double system)
turbo	Garret T3 + intercooler
catalytic converter	three-way with Lambda sensor metal monolith
<b>TRANSMISSION</b>	
propulsion	rear wheels
gearbox type	5-speed manual
gearbox ratios:1st	3.36 : 1
2nd	1.81 : 1
3rd	1.26 : 1
4th	1.00 : 1
5th	0.82 : 1
reverse	3.66 : 1
final drive	3.62 : 1
<b>BODY / CHASSIS</b>	
body	aluminium with fibreglass wings and nose cone
chassis	space frame
front suspension	independent by double wishbones and anti-roll bar
rear suspension	independent by double wishbones and trailing arms
springs and shock absorbers	progressive coil springs with adjustable Koni shock absorbers
front brakes	ventilated discs
rear brakes	drums
brake circuit	dual front/rear
brake adjustment	by a balance bar, acting on two master cylinders
brake fail system	by a differential valve with warning light on dashboard
handbrake	mechanical on rear wheels
wheels	alloy revolution comp. specially made, 8"x15"
tyres	low section radial 205/225/50x15
steering	rack and pinion
number of turns lock to lock	3.25
steering wheel diameter	11" or 12"
<b>DIMENSIONS AND WEIGHTS</b>	
overall length	3.60 m
overall width	1.73 m
overall height	1.10 m
track, front/rear	1.40/1.47 m
turning circle	8 m
unladen weight	685 kg
max. load front axle	400 kg
max. load rear axle	525 kg
fuel tank capacity	45 l
<b>PERFORMANCE / FUEL CONSUMPTION</b>	
acceleration 0-100 km/h	5.0 sec.
top speed	220 km/h
fuel consumption at 100 km/h	7 l/100 km
overall consumption	11.5 l/100 km

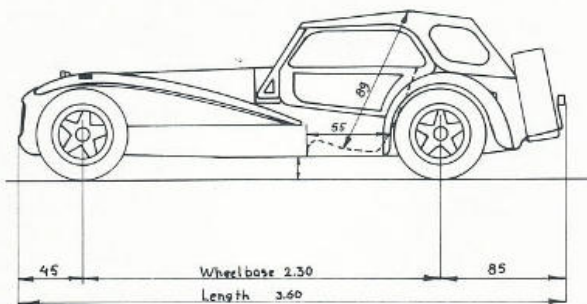
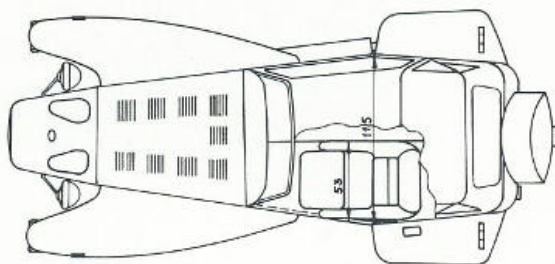
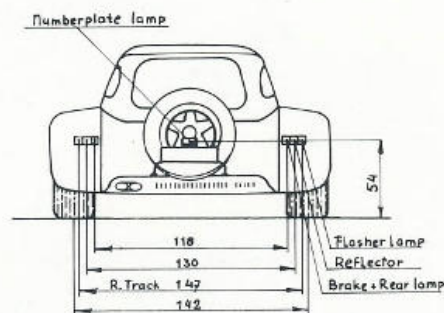
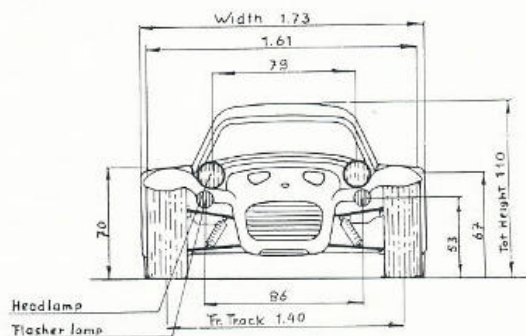

JOOP DONKERVOORT  
 NIEUW LOOSDRECHTSEDIJK 205 A  
 NL - 1231 KT NIEUW LOOSDRECHT  
 HOLLAND  
 TEL. 02158 - 1990  
 FAX: 02158 - 4585

Sarl S. B. M.  
 Petit faubourg  
 01190 PONT DE VAUX  
 Tel 85 30 31 26